

**NATIONAL BUSINESS AND TECHNICAL EXAMINATIONS BOARD NATIONAL TECHNICAL CERTIFICATE EXAMINATION**

Question 1

**BASIC ELECTRICITY**

- 1a. (i) State ONE application of a capacitor  
 (ii) Capacitors  $8\mu\text{f}$ ,  $12\mu\text{f}$  and  $20\mu\text{f}$  are connected in a circuit. Calculate the resultant capacitance when connected in:  
 (i) Series  
 (ii) Parallel
- b. State the factors which affect the resistance of a conductor

Solutions

- (a) (i) Capacitor is used to store electric charges smoothing, power factor correction, motor starters etc  
 (ii) In series



$$\begin{aligned} \frac{1}{C_T} &= \frac{1}{C_1} + \frac{1}{C_2} + \frac{1}{C_3} \\ &= \frac{1}{8} + \frac{1}{12} + \frac{1}{20} \\ &= \frac{15+10+6}{120} = \frac{31}{120} \\ \Rightarrow C_T &= \frac{120}{31} = 3.97\mu\text{f} \\ \therefore C_T &= \underline{3.87\mu\text{f}} \end{aligned}$$

- (iii) Parallel

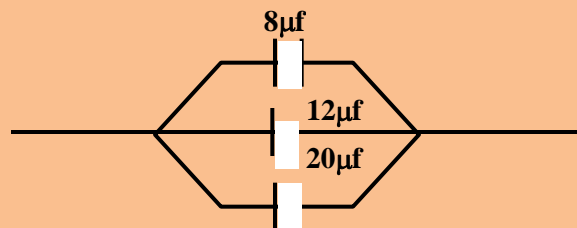

$$\begin{aligned} C_T &= C_1 + C_2 + C_3 \\ &= (8 + 12 + 20)\mu\text{f} \\ \therefore C_T &= \underline{40\mu\text{f}} \end{aligned}$$

- (b) Factors that affect the resistance of a conductor
- ❖ The nature of the conductor
  - ❖ The length of the conductor

- ❖ The cross sectional area of the conductor
- ❖ The temperature of the conductor
- ❖ The resistivity of the conductor

$$R \propto L, \quad R \propto \frac{L}{A}, \quad R \propto \frac{L}{A}$$

$$\therefore R = \frac{eL}{A} \text{ where } \begin{array}{l} R = \text{Resistance of the conductor} \\ L = \text{Length of the conductor} \\ A = \text{cross sectional area of the conductor} \\ e = \text{Resistivity (proportionality constant)} \end{array}$$

### Question 2

- 2a. Three resistors of resistance  $10\Omega$ ,  $15\Omega$  and  $60\Omega$  are connected in series. Another resistor of  $17\Omega$  is connected in parallel with the series group. Calculate the total resistance of the combination
- b. What are the characteristics of voltage and current in a series circuit?

### Solution

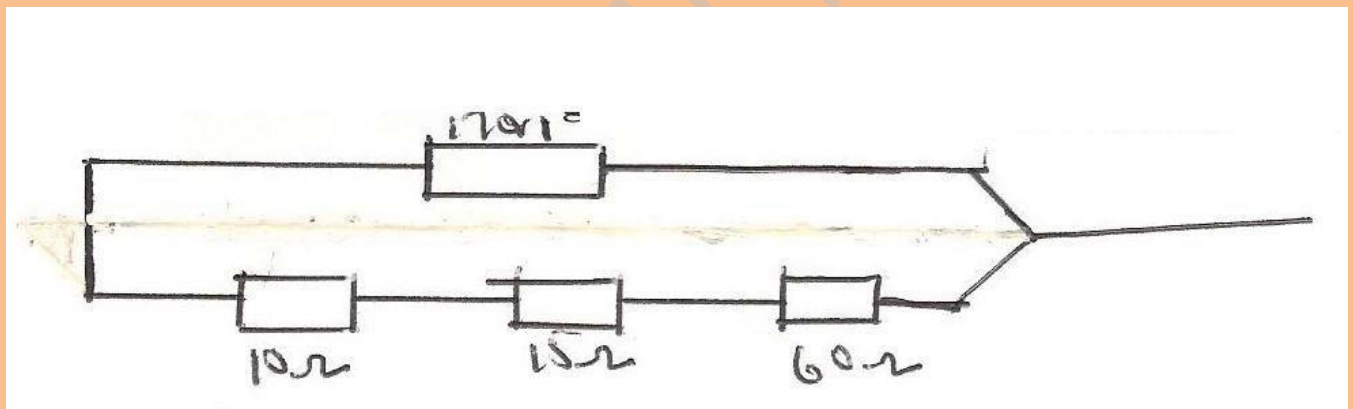

$$\begin{aligned} R_s &= R_1 + R_2 + R_3 \\ &= 10 + 15 + 60 \\ &= \underline{85\Omega} \end{aligned}$$

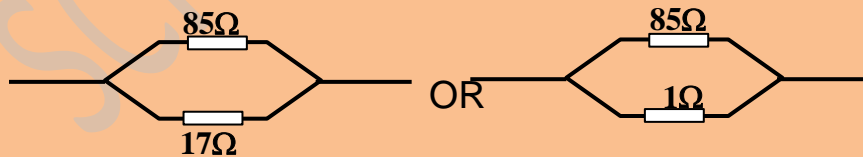

$$\frac{1}{R_p} = \frac{1}{R_1} + \frac{1}{R_2} \quad \text{OR} \quad \frac{1}{R_p} = \frac{1}{R_1} + \frac{1}{R_2}$$

$$1 = 1 + 1 \quad 1 = 1 + 1$$

SCHOOL PORTAL NG . COM

$$R_p = \frac{85 \times 17}{85 + 17} = \frac{1445}{102}$$

$$\therefore R_p = 14.17\Omega$$

$$R_p = \frac{85 \times 1}{85 + 1} = \frac{85}{86}$$

$$\therefore R_p = 0.99\Omega$$

- b. Characteristics of voltage and current in a series circuit
- (i) The p.d across each resistor is different
  - (ii) The p.d across each resistor is less than the total p.d across the whole circuit
  - (iii) The current in all the resistors/lamp is the same
  - (iv) Total p.d the sums of the pds across the resistors

### Question 3

- 3a. (i) Define electromotive force  
 (ii) State the unit and symbol of electromotive force
- b. A dry cell of emf 3v and an internal resistance of  $0.5\Omega$  is connected to a load resistance of  $7\Omega$   
 calculate  
 (i) the load current  
 (ii) the voltage drop across the internal resistance

### Solution

- a. (i) electromotive force is defined as the potential difference (p.d) between the terminals of a cell when it is not delivering any current to the circuit or defined as the total energy generated per coulomb or defined as the p.d across the terminals of a cell on open circuit

$$E = V + I$$

- (ii) The unit is volts (v) and the symiol is E

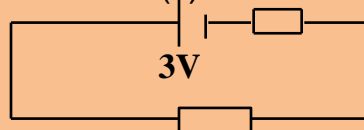

7Ω

SCHOOL PORTAL NG . COM

$$\begin{aligned} \text{Emf (E)} &= 3\text{V}, \quad r = 0.5\Omega, \quad R = 7.0\Omega \\ \text{(i) Load current, } I &= \frac{E}{R+r} \\ I &= \frac{3}{7+0.5} = \frac{3}{7.5} \\ I &= \underline{0.4\text{A}} \end{aligned}$$

(ii) Voltage across the internal resistance,  $I_r$  is given as

$$\begin{aligned} I_r &= 0.4 \times 0.5 \\ &= \underline{0.2\text{v}} \end{aligned}$$

#### Question 4

4. a. State the factors which affect the resistance of a conductor  
 b. Determine the range of resistance of a resistor which has the following colour codes; Blue, Black Red and Silver  
 c. Two resistance of values  $10\Omega$  and  $20\Omega$  are connected in parallel across a  $240\text{v}$  battery  
 (i) The total resistance  
 (ii) The total current  
 (iii) The energy consumed in the  $12\Omega$  resistor

#### Solution

- a. Factors that affect the resistance of a conductor

- ❖ The nature of the conductor
- ❖ The length of the conductor
- ❖ The cross sectional area of the conductor
- ❖ The temperature of the conductor
- ❖ The resistivity of the conductor

$$\begin{aligned} R \propto L, \quad R \propto \frac{L}{A} \quad R \propto \frac{\rho L}{A} \\ \therefore R = \frac{\rho L}{A} \end{aligned}$$

Where  $\rho$  = resistivity of the conductor  
 $L$  = length of the conductor  
 $A$  = cross sectional area of the conductor  
 $R$  = resistance of the conductor

- b. 

Blue	Black	Red	Silver
6	0	2	10%
6	0	00	10%
6000	$\pm$	10%	
10%	=	0.1	
6000 $\pm$ 10%	=	5,400 or 6,600	

- c.

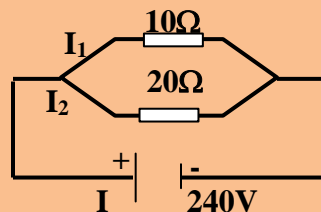

(i) Total Resistance

$$\frac{1}{R_T} = \frac{1}{R_1} + \frac{1}{R_2} = \frac{1}{10} + \frac{1}{20} = \frac{2+1}{20} = \frac{3}{20}$$

$$\Rightarrow R_T = \frac{20}{3} = \underline{6.67\Omega}$$

$$\therefore R_T = \underline{6.67\Omega}$$

(ii) Total current

$$I_T = \frac{V}{R_T} = \frac{240}{6.67}$$

$$I_T = \frac{240}{6.67} = 35.98$$

$$\therefore I_T = \underline{35.98A}$$

(iii) The energy consumed in each resistor in iminute

$$I_1 = \frac{V}{R_1} = \frac{240}{10} = 24A$$

$$I_2 = \frac{V}{R_2} = \frac{240}{20} = 12A$$

$$\Rightarrow E_{10} = Ivt = 24 \times 240 \times 60 = 345600$$

$$\therefore E_{10} = \underline{345.600J}$$

$$\text{also, } E_{20} = Ivt = 12 \times 240 \times 60 = 172800$$

$$\therefore E_{20} = 172.800J$$

### Question 5

5. Draw the B.S. symbols of the following

i. Electric Bell



ii. Discharge lamp





iii. One way switch

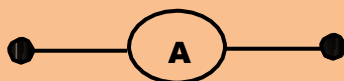

iv. Ammeter



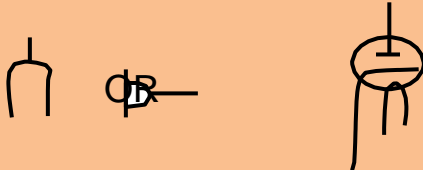
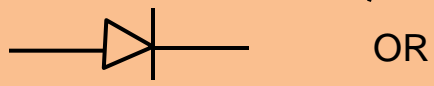
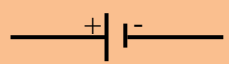

- v. Electric fan 
- vi. Variable capacitor 
- vii. Socket 
- viii. Diode 
- ix. Cell 
- x. Auto-transformer

### Question 6

- 6a. i. Define capacitance  
 ii. State the THREE factors that determine the capacitance of a capacitor
- b. Three capacitors of values  $6\mu\text{f}$ ,  $10\mu\text{f}$  and  $14\mu\text{f}$  respectively are connected in series across 10V d.c source. Determine
- The total capacitance of the group
  - The total charge stored by the capacitors
  - The energy stored in the circuit.

### Solution

- ai. Capacitance is the property of an isolated conductor or sets of conductor and insulator to store electric charge. It is defined as the ability of a capacitor to store electric charges. It can also be defined as the ratio of the amount of electricity (charge) to the potential difference (p.d) produced between the plates. It is symbolized by letter C and measured in farad (f). capacitance,  $C = Q/V$ .
- ii. There factors that determine the capacitance of a capacitor.
- The effective surface area of overlap of the two parallel plates.  $C \propto A$
  - The distance between the plates, ie  $C \propto \frac{1}{d}$
  - $C \propto \frac{A}{d}$  and  $C = \frac{\epsilon A}{d}$

b.

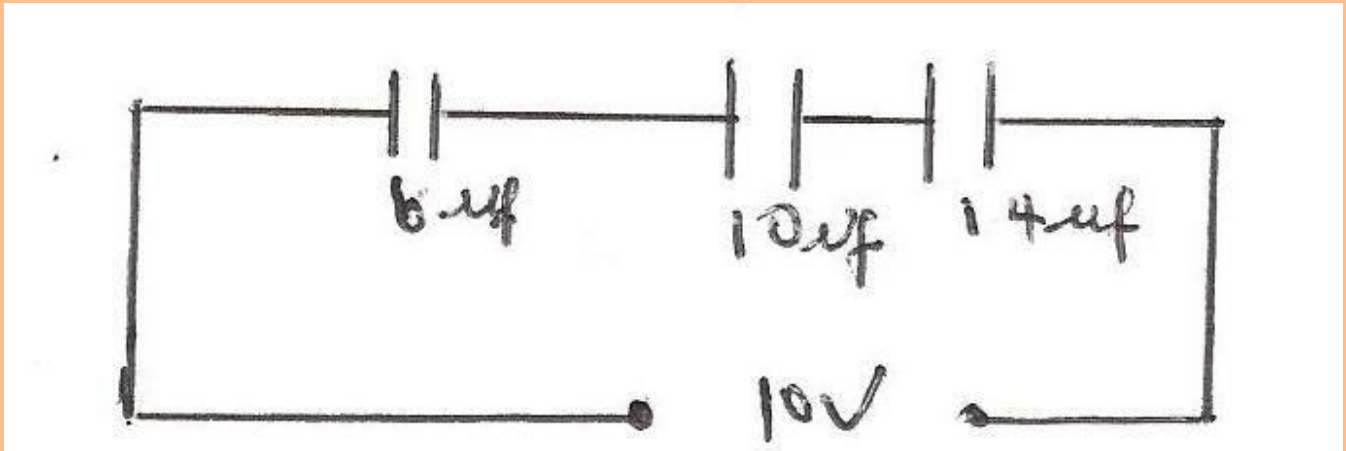

i. The total capacitance of the group

$$\begin{aligned} \frac{1}{C} &= \frac{1}{C_1} + \frac{1}{C_2} + \frac{1}{C_3} \\ &= \frac{1}{6} + \frac{1}{10} + \frac{1}{14} \\ &= \frac{140+84+60}{840} = \frac{284}{840} \\ \Rightarrow \frac{1}{C} &= \frac{284}{840} \\ \Rightarrow C &= \frac{840}{284} = 2.96 \mu\text{f} \end{aligned}$$

$$\therefore C = 2.96 \mu\text{f}$$

ii. Total charge stored by the capacitor

$$\begin{aligned} C &= \frac{Q}{V} \\ Q &= CV = 2.96 \times 10^{-6} \times 10 \\ \therefore Q &= \underline{2.96 \times 10^{-5} \text{ C}} \end{aligned}$$

iii. The Energy stored in the circuit

$$\begin{aligned} W &= \frac{1}{2} VQ \text{ or } \frac{1}{2} CV^2 \text{ or } \frac{1}{2} \frac{Q^2}{C} \\ \text{ie } W &= \frac{10 \times 2.96 \times 10^{-5}}{2} \\ \therefore W &= \underline{1.48 \times 10^{-4} \text{ J}} \end{aligned}$$

### Question 7

7a. Define the following terms and state their units and symbols:

- i Impedance
- ii Inductive reactance
- iii Capacitive reactance
- iv Resistance

b. A coil of resistance  $30\Omega$  and inductance  $0.08\text{H}$  are connected to a supply of  $240\text{V}$ ,  $50\text{Hz}$

Calculate the:

- i Impedance
- ii Current in the circuit
- iii Value of the capacitance to be connected in series with the coil so that the current shall be 12amps.

Solution

Ai. Impedance is defined as the total or effective opposition offered to the flow of an alternating current due to the presence of an inductor (inductance coil), a capacitor and a resistor in an A C circuit. The unit of impedance is ohms ( $\Omega$ ) and the symbol is Z

Where Z

$$Z = \sqrt{R^2 + X_L^2} \quad \text{or} \quad \sqrt{R^2 + X_C^2} \quad \text{or} \quad \sqrt{R^2 + (X_L - X_C)^2}$$

- ii Inductive reactance is defined as the opposition to an alternating current due to the presence of an inductor in an A.C. circuit. The unit is ohms ( $\Omega$ ) and the symbol is  $X_L$  where  $X_L = 2\pi fL$
- iii. Capacitive Reactance is defined as the opposition to an alternating current due to presence of a capacitor in the circuit. The unit is ohms ( $\Omega$ ) and the symbol is  $X_C$ , where  $X_C = \frac{1}{2\pi fL}$
- iv. Resistance is defined as the opposition which the components or elements or material in a pre resistive circuit offers to the flow of current in a circuit Resistance is represented by a letter R and the unit is ohms ( $\Omega$ )

b.

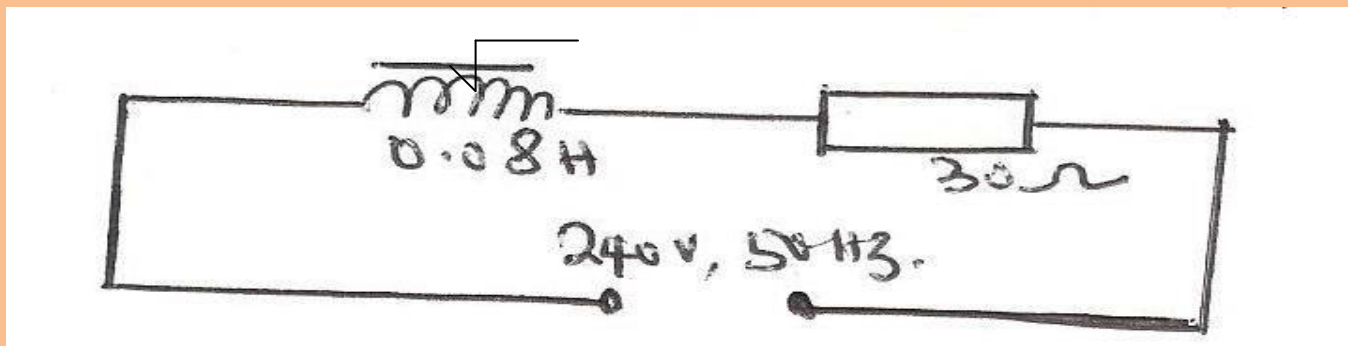

- i. Impedance,  $Z = \sqrt{R^2 + X_L^2}$   
 But  $X_L = 2\pi fL$   
 $= 2 \times 3.142 \times 50 \times 0.08$   
 $X_L = 25.136$   
 $= 25.14\Omega$   
 $Z = \sqrt{R^2 + X_L^2}$   
 $= \sqrt{30^2 + 25^2}$   
 $= \sqrt{900 + 625}$

$$\begin{aligned} &= \sqrt{1525} \\ \therefore Z &= \underline{39.1\Omega} \end{aligned}$$

ii Current, I in the circuit

$$I = \frac{V}{Z} = \frac{240}{39.1} = 6.15$$

$$\therefore I = \underline{6.15A}$$

iii

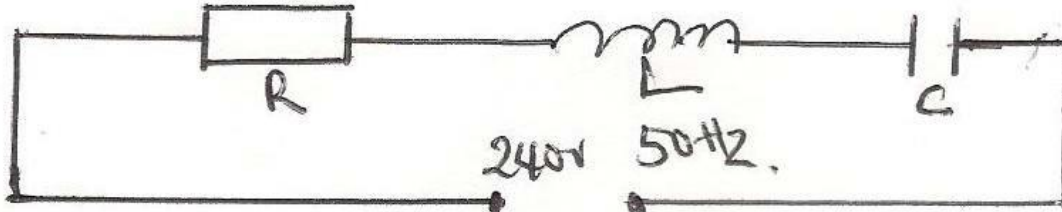

$$\text{Current, } I = 12A$$

$$Z = \frac{V}{I} = \frac{240}{12} = 20\Omega$$

The only assumption by which this problem can be solved is to consider a point of resonance. Why?

$$\begin{aligned} \text{ie } X_L &= X_C \\ 2\pi fL &= \frac{1}{2\pi fC} \\ 4\pi^2 f^2 LC &= 1 \\ C &= \frac{1}{4\pi^2 f^2 L} \end{aligned}$$

$$= \frac{1}{4 \times (3.142)^2 \times (50)^2 \times 0.08}$$

$$= \frac{1}{7895.6}$$

$$= 0.0001266$$

$$\therefore C = \underline{1.3 \times 10^{-4} F}$$

It could also be solved by this process that  $Z = \sqrt{R^2 + (X_L - X_C)^2}$

